

Production of advanced biofuels: Co-processing of upgraded pyrolysis oil in standard refinery units

F. de Miguel Mercader^{a,*}, J.A. Hogendoorn^a, S.R.A. Kersten^a, N.W.J. Way^b, C.J. Schaverien^b, M.J. Groeneveld^a

^a Thermo-Chemical Conversion of Biomass Group, Faculty of Science and Technology, University of Twente, P.O. Box 217, 7500AE Enschede, The Netherlands.

^b Shell Global Solutions International, Grasweg 31, 1031 HW Amsterdam, The Netherlands.

* Corresponding author: Tel.: +31 53 489 4063, E-mail address: f.demiguelmercader@utwente.nl

Abstract

One of the possible process options for the production of advanced biofuels is the co-processing of upgraded pyrolysis oil in standard refineries. The applicability of hydrodeoxygenation (HDO) was studied as a pyrolysis oil upgrading step to allow FCC co-processing in standard refineries. Different HDO reaction end temperatures (230-340 °C) were evaluated in a 5 L autoclave, keeping the other process conditions constant (total 290 bar, 5 wt. % Ru/C catalyst), in order to find the required oil product properties necessary for successful FCC co-processing (miscibility with FCC feed and good yield structure: little gas/coke make and good boiling range liquid products). After HDO, the upgraded pyrolysis oil undergoes phase separation resulting in an aqueous phase, some gases (mainly CO₂ and CH₄), and an oil phase that was further processed in a Micro Activity Test (MAT) reactor (simulated FCC reactor). Although the oil and aqueous phase yields remained approximately constant when the HDO reaction temperature was increased, a net transfer of organic components (probably hydrodeoxygenated sugars) from the aqueous phase to the oil phase was observed, increasing the carbon recovery in the oil product (up to 70 wt. % of the carbon in pyrolysis oil).

The upgraded oils were subsequently tested in a lab scale catalytic cracking unit (MAT reactor), assessing the suitability of HDO oils to be used as FCC feed. In spite of the relatively high oxygen content (from 17 wt. % to 28 wt. %, on dry basis) and the different properties of the HDO oils, they all could be successfully dissolved in and co-processed (20 wt. %) with a Long Residue, yielding near normal FCC gasoline (44-46 wt. %) and Light Cycle Oil (23-25 wt. %) products without an excessive increase of undesired coke and dry gas, as compared to the base feed only. Near oxygenate-free bio-hydrocarbons were obtained, probably via hydrogen transfer from the Long Residue. In this way, we have demonstrated on a laboratory scale that it is possible to produce hydrocarbons from ligno-cellulosic biomass via a pyrolysis oil upgrading route. The much higher coke yields obtained from the catalytic cracking of undiluted HDO oil showed the importance of co-processing using a refinery feed as solvent and hydrogen transfer source.

1. Introduction

First generation biofuels (bioethanol and biodiesel) are currently being used in many countries. Their utilisation can contribute to secure the supply of fuels and to the reduction of green-house-gas emissions, although the net energy value of some of them has been strongly questioned [1]. Advanced biofuels not only have the same advantages as the previously mentioned fuels, but also they do not compete with the food chain and they can be produced from a wider range of ligno-cellulosic biomass, including agricultural waste, wood, forest residues, etc.. Several options are under development to produce advanced biofuels. Biomass can be gasified to produce synthesis gas followed by e.g. a Fischer Tropsch process. The process proposed in this work consists of co-processing upgraded pyrolysis oil from ligno-cellulosic biomass in standard refinery units. The advantages of this process are:

- The use of decentralised pyrolysis plants that can be near the biomass production site. This means only the oil is transported (reducing transportation costs due to the increase of the volumetric energy of the oil compared to the original biomass).
- After pyrolysis, large part of the minerals from biomass is not transferred to the oil but remain as ash. Thus, pyrolysis oil contains less inorganic material that could poison subsequent catalytic processes. Moreover, the ash can be returned to the soil as fertiliser.
- As the upgrading plant would be next to (or inside) the refinery, all the necessary utilities would be already available and the product obtained after co-processing could use the existing distribution network.

During fast (or flash) pyrolysis, dry solid biomass is rapidly heated to temperatures around 400-500 °C in the absence of oxygen, converting it into a liquid oil with yields up to 70-80 wt. % [2]. Char (~ 5-10 wt. %) and gas (~20-30 wt. %) are also produced. Pyrolysis oil (or bio-oil) is a mixture of oxygenated compounds formed during the decomposition of lignin and (hemi-)cellulose and water (generated during the process and from the initial moisture content of the biomass). The oxygen content is typically 45-50 wt. % and the water content 15-30 wt. % [2]. Because of this, the heating value of pyrolysis oil (HHV ~ 17 MJ/kg [2]) is low compared to fossil fuels (HHV ~ 45 MJ/kg). All these properties make the direct co-processing of pyrolysis oil itself in standard refinery units problematic. Several pyrolysis process modifications are currently being studied (hot-gas vapour filtration [3], catalysis [4]) to obtain an oil with better properties. In this study, pyrolysis oil from standard flash pyrolysis has been used as feed for upgrading.

Various upgrading routes have been studied until now: hydrodeoxygenation (HDO) to remove the oxygen as water under high pressures of hydrogen and in the presence of a catalyst [5]; catalytic cracking using zeolites [6]; and high pressure thermal treatment (HPTT), in which pyrolysis oil is thermally treated to obtain an oil with a higher energy density [7]. Previous research on HDO suggested that a two stage process is preferred to prevent excessive coke formation during HDO [8]. In the first step at relatively low temperature (~150-175 °C), pyrolysis oil is stabilised and in a second step at higher

temperature (~350-380 °C) deep deoxygenation (> 95%) could be achieved [9]. The main concern about this process is the high hydrogen consumption (> 800 NL/kg feed). After catalytic cracking of crude pyrolysis oil, gasoline range products were obtained [10]. However, at low temperatures (370 °C) the amount of oxygenated compounds was high and at higher temperatures (410 °C), the production of coke and gas increased at the expense of the gasoline yield [11]. During HPTT of pyrolysis oil, phase separation occurs producing an aqueous phase (15-35 wt. % dry basis), an oil phase (55-65 wt. % dry basis), gas (0-10 wt. % dry basis) and water (5-15 wt. % dry basis). Experimental results showed that, with increasing temperatures, the release of gases (mainly CO₂) and the production of water increased, reducing the oxygen content (from 40.1 wt. % to 20.0 wt. %, on dry basis) of the oil phase and hence increasing the energy content (from 14.1 to 28.4 MJ/kg). This increase of energy density was due to the transfer of organic components from the aqueous phase to the oil phase. However, an increase of the average molecular weight of the oil, probably caused by the polymerisation of the sugar constituents of the oil, was also detected [7].

Baldauf et al. [12] proposed the use of hydrotreated pyrolysis oil in standard refineries. From the properties of the hydrotreated pyrolysis oil, they concluded that it should be sent to the distillation tower where the fractions could be diluted in different refinery cuts and be sent for further processing. Co-processing of upgraded pyrolysis oil was studied by Samolada et al. [13]. In their research, a heavy and a light fraction were obtained by thermal hydrotreatment of flash pyrolysis oil (Union Fenosa, Spain). The heavy fraction, with an oxygen content of 4.9 wt. % (wet basis), was catalytically cracked in a MAT reactor, with a dilution ratio of 15/ 85 heavy fraction / LCO (in weight basis). They obtained gasoline yields between 20-25 wt. % and coke yields between 0.8 and 1.4 wt. %. Lappas et al. [14] co-processed the same heavy fraction as Samolada et al. but diluting it in LCO and VGO. The product yields of co-processing were approximately 1 wt. % higher for gasoline and LCO and 0.5 wt. % higher for coke, compared to the yields obtained after catalytic cracking of pure VGO. UOP LLC [15] patented a process for the hydrotreatment of the pyrolysis oil lignin fraction and the subsequent hydrocracking of the organic phase product. (oxygen content of 5.9 wt. %), obtaining a gasoline yield of 30 wt. % (from the original lignin fraction).

In this paper, the results of the hydrodeoxygenation of pyrolysis oil and the subsequent co-processing in a lab scale FCC ebullating bed reactor are presented and discussed.¹ In the first part, the effect of different experimental HDO conditions on the product yield and properties are shown. In the second part, the co-processing of the HDO oils with Long Residue oil in a lab scale catalytic cracking reactor is evaluated. In this manner, a link between the HDO step (process conditions and oil product properties) and the catalytic cracking product yields can be established.

¹ The work described in this paper has been carried out within the framework of BIOCUP [16]. Within the same project, the Biomass Technology Group (BTG) has prepared HDO oils using a packed bed reactor with similar subsequent co-processing.

2. Experimental section

2.1. Materials

The pyrolysis oil used in the present work was produced in a 20 kg/h process development unit from VTT, Finland [17]. The feedstock used to produce it was forest residue. i-Propanol (2 wt. %) was added to the freshly prepared oil to increase homogeneity. A top phase (10.6 wt. %) including most of the extractives was separated. A specification of the remaining phase, as used in the HDO upgrading experiments, is given in [Table 1](#).

Table 1. Forest residue pyrolysis oil (bottom phase) properties (supplied by VTT)

Property	Forest residue pyrolysis oil (bottom phase)
Water (wt. %) ^a	25.0
Solids (wt. %)	0.04
Nitrogen (wt. %)	0.2
Sulphur (wt. %)	0.01
Carbon (wt. %) ^a	40.7
Hydrogen (wt. %) ^a	8.04
Viscosity, 40 °C (cSt)	16
Density, 15 °C (kg/l)	1.196
HHV (MJ/kg)	16.8
LHV (MJ/kg)	15.5
pH	2.6
^a Analyses performed at University of Twente	

The catalyst used in HDO experiments was ruthenium supported on carbon powder, as this has found to be a good and stable deoxygenation catalyst [18]. It was supplied by Sigma-Aldrich with a metal loading of 5 wt. % and a particle size of around 22 µm. It was used without any further pre-treatment.

Within the project this research takes part [16], studies on other catalysts are ongoing [19, 20].

For the co-processing experiments, a Long Residue from one of Shell's refineries was used.

2.2. Experimental set-ups and procedure

Pyrolysis oil upgrading experiments were carried out in a stirred autoclave (Andreas Hofer, Germany) with a total volume of 5 litres, which was placed inside a high pressure box for safety reasons. The maximum operating temperature and pressure were 350 °C and 340 bar, respectively. [Figure 1](#) shows the flow diagram of the set-up. In a typical experiment, pyrolysis oil (2.5 kg approximately) was loaded into the reactor

followed by 5 wt. % of fresh (unused) catalyst. The autoclave was closed and flushed with nitrogen to remove air and a first leak test was performed. If no leakage was detected, the nitrogen was vented and a second leak test using H₂ was performed at the same pressure as the reaction would take place. When the test was successful, the hydrogen was vented. A hydrogen supply vessel was used to feed the autoclave so quantification of the hydrogen consumption (rate) during the experiment was possible. This H₂ supply vessel had a volume of 10.8 L and it was typically loaded with an initial pressure of 400 bar. The autoclave was filled with H₂ until the desired starting pressure (typically 200 bar) and the valve between the reactor and the supply vessel was closed. Then, the electrical heating jacket and the high intensity hollow shaft stirrer (2000 rpm) were turned on. The typical heating rate was approximately 5.5 °C/min until 270 °C, being slower after that (~4 °C/min). This meant that it took from 1 to 2 hours to reach the desired reaction temperature. Because of the increase of temperature during heating, the total pressure initially increased until the hydrogen started to dissolve/react faster than the pressure increase caused by temperature. At this moment, more hydrogen was added to the reactor until the desired reaction pressure was reached (typically 290 bar). This pressure was regulated by a reducing valve. Strong hydrogen consumption was always observed at temperatures between 150 and 200 °C, the temperature at which the stabilization is claimed to occur [9]. Therefore, the 'stabilization step' at lower temperature as reported in literature is thus an integrated, though not controlled, part of the experiment. A typical temperature profile as a function of time and the accompanying hydrogen consumption is given in [Figure 2](#). The total reaction time at the desired end temperature (referred as reaction temperature) was set for all the experiments at four hours (excluding heating time). This reaction time was selected following the findings of Wildschut [18], which showed that at 350 °C and 200 bar the oil yield was maximized. After 4 hours, the heating and the H₂ supply were stopped and the stirrer was left on for 30 min more. The whole system was left to cool down overnight. The final pressure and temperature of the reactor and the supply vessel were recorded, a gas sample was taken for analysis purposes and the system depressurised. After HDO, the liquid product consisted of either two or three phases (depending on the exact process conditions). If a three phase product was obtained, the top layer contained light organic components (top oil), the middle layer consisted mainly of water with some dissolved organics (aqueous phase) and the bottom layer was again organic and contained most of the catalyst (bottom oil). The product phases were separated, quantified and analysed.

Hydrogen consumption was calculated from the difference in pressure of the supply vessel between the beginning and the end of the experiment minus the hydrogen that remained un-reacted inside the autoclave before it was opened. To calculate the amount of hydrogen consumed, the density of hydrogen in the conditions of the supply vessel and reactor was needed. The Soave equation of state was used [21] to determine this value. This equation gave the smallest error (~ 0.5 mol %) at the conditions of the supply vessel when compared to values determined experimentally [22]. Other equations like Peng-Robinson, Van der Waals and ideal gas gave errors up to 5 mol %, 7 mol % and 25 mol %, respectively.

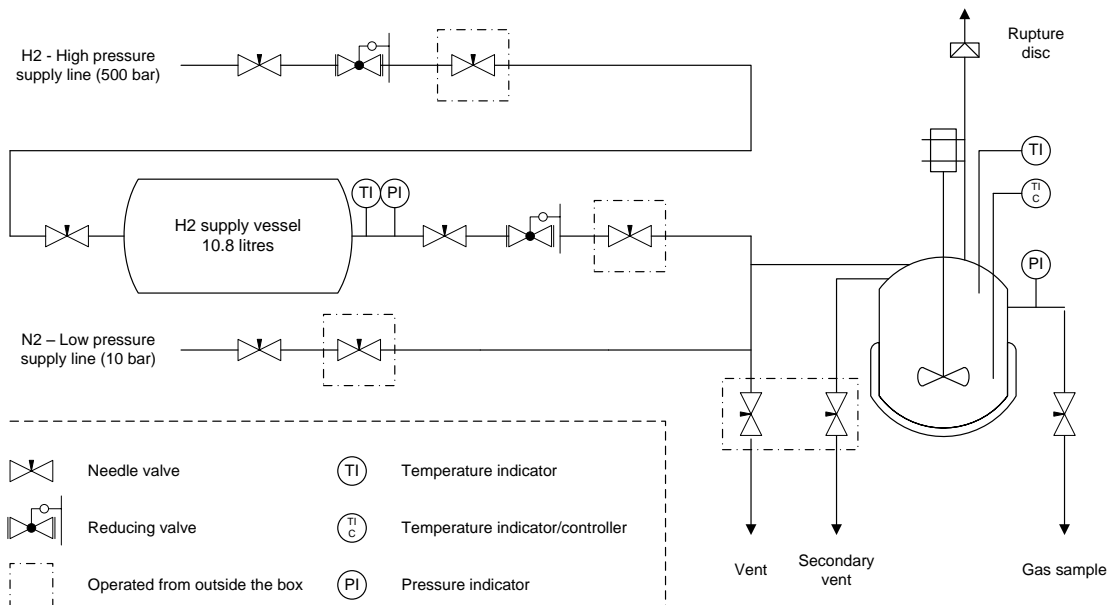

Figure 1. Flow diagram of the HDO set-up.

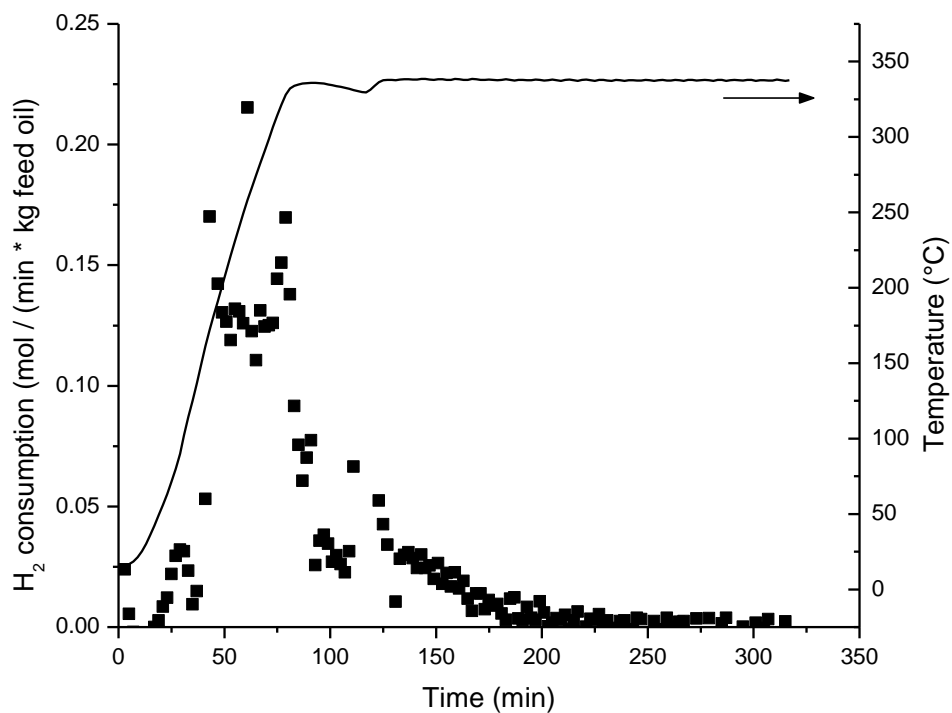

Figure 2. Typical hydrogen consumption rate and temperature profile of an HDO experiment

The HDO oils were filtered (5 μ m steel wire mesh filter) to remove the Ru/C catalyst.

The fluidised bed MAT-5000 reactor is designed for unattended, automated operation and on-line GC product analysis of seven Cat/Oil ratios (3, 4, 5, 6, 6.5, 7 and 8) with in-situ catalyst regeneration. 10 g of a FCC equilibrium catalyst is constantly fluidised with nitrogen. The feed (Long Residue, HDO oil or mixtures thereof) intake was varied to obtain results at different cat/oil ratios. After cracking, liquid products are collected in glass vessels at $-15\text{ }^{\circ}\text{C}$. The gas fraction is analysed by on-line GC. After stripping, the catalyst is regenerated, converting the coke to CO_2 , which is quantified by on-line infrared measurements. Experiments are only deemed valid for mass balances 98 ± 4 wt. %. Gasoline is defined as $\text{C}_5 - 221\text{ }^{\circ}\text{C}$, Light Cycle Oil as $221 - 370\text{ }^{\circ}\text{C}$, Heavy Cycle Oil as $370 - 425\text{ }^{\circ}\text{C}$ and Slurry Oil as $> 425\text{ }^{\circ}\text{C}$.

2.3. Analyses

The gas sample obtained at the end of an HDO experiment was analysed using a Varian Micro GC CP-4900 with three analytical columns: 10m Molsieve 5A and 10m PPQ using helium as carrier gas and 10m Molsieve 5A using argon as carrier gas for better hydrogen quantification.

For the HDO liquid products, the elemental composition (Fisons Instruments 1108 EA CHN-S), the water content (787 KF Titrino), the molecular weight distribution (Agilent HPLC 1200, with GPC columns) and the viscosity (Brookfield DV-E viscometer) were determined. More details about the equipment and reactants can be found elsewhere [7].

The solvent fractionation technique developed by VTT was used to fractionate the HDO aqueous phase product. The main components found in each fraction are:

- Water insoluble fraction: solids, extractives, lignin and polymerisation products.
- Ether insoluble fraction: mainly sugars.
- Ether soluble fraction: aldehydes, ketones and lignin monomers.

Although this technique does not give individual component information, it is of good utility to identify changes in the major fractions of pyrolysis oil and upgraded products. More details about this fractionation technique can be found in the article of Oasmaa et al. [23].

Micro carbon residue tests (MCRT), a kind of Conradson carbon test, were performed on the HDO oils, the Long Residue and mixtures thereof, following the ASTM D4530 standard.

The product obtained after co-processing was analysed using true boiling point (TBP) following the ASTM D2887 standard. From this simulated distillation, the different oil fractions yields could be quantified.

3. Experimental results

3.1. Hydrodeoxygenation of pyrolysis oil

A series of experiments with maximum reaction temperatures between 230 and 340 °C was carried out. The total pressure was kept constant at around 290 bar because of the vapour pressure of the components present, especially water, and the gas production. The hydrogen partial pressure is expected to decrease with experimental temperature and in the course of an experiment.

As already indicated, after HDO, a product with either two or three phases (depending on the exact process conditions) was obtained. For the experiments carried out at temperatures lower than 300 °C, only bottom oil and an aqueous phase were produced. At 300 °C three clearly distinguishable phases were obtained. No significant differences (elemental composition and molecular weight distribution) could be found between the top and bottom oil. At temperatures higher than 300 °C, three phases were produced, but the amount of bottom phase (also containing the catalyst) was reduced and had a paste-like appearance. When some of this bottom phase was filtered, the product became top oil. This can be explained when assuming that part of the components with a lower density than the aqueous phase adhered to the catalyst forming the paste-like material that sank the oil to the bottom. It appears that at high temperatures only top oil was produced. Therefore, because the process was carried out in slurry and it was difficult to know which parts of this organics were belonging to top or bottom layer (except when only two phases were obtained), the product yields for the oil are shown as the sum of the yields for the top and bottom layer. If coke was produced during the process, it could not be distinguished from the catalyst support and it would be accounted as oil phase (coke yield is expected to be lower than 5 wt. % [18]).

The mass balance closure was typically between 91 and 97 wt. % (dry basis). [Table 2](#) shows the yields and elemental composition of the oil product and gas composition. By increasing the reaction temperature, the yields of gas and water produced increased due to the increase of the decarboxylation/methanation and hydrodeoxygenation/dehydration reaction rates, respectively. From the gas composition, up to 25 mol % methane is present in the gas phase, which is expected from using a ruthenium-based catalyst [24]. The total gas yield is, however, relatively low, having a maximum of 7 wt. % at 340 °C. The oil yield appeared to be independent of temperature and the decrease of organics in the aqueous phase seems to be mainly due to their transfer to water and gas. However, this is an artefact due to the removal of oxygen from the oil. [Figure 3](#) clearly illustrates that, indeed, carbon was being transferred from the aqueous phase to the oil phase and not only transferred to the gas phase. The carbon recovery in the oil phase increased from 55% at 230 °C to 70% at 340 °C. This can be explained by the hydrodeoxygenation of water soluble organic components that reduced their polarity and increased their oil affinity. Consequently, the hydrogen consumption also increased with the reaction temperature from 232 to 326 NL H₂/kg of feed oil. If, however, hydrogen use is expressed in NL/HHV_{product oil} then hydrogen consumption

remains approximately constant and almost independent of temperature at ~ 22 NL/ MJ (see [Table 2](#) for exact hydrogen use). This way of calculating H₂ consumption also takes into account the yield of product oil and its properties (HHV is directly related to elemental composition and water content [25]), making this value more significant when evaluating the process requirements.

Table 2. Dry product yields and oil properties after HDO at different temperatures (residence time: 4 h, total pressure 290 bar).

Temperature (°C)	230	260	300	330	340
Dry yields^a (wt. % of dry feed)					
Top oil + Bottom oil	47	49	50	48	50
Aqueous phase	39	33	26	16	14
Gas	3	4	4	3	9
Water produced	9	10	13	19	18
Mass balance closure	97	96	92	86	91
H₂ consumption					
NL H ₂ /kg feed oil	232	237	290	297	326
NL H ₂ /kg C in product	1031	1059	1098	1089	1153
NL H ₂ /MJ of product	21.6	22	22.3	21.8	23.6
Product properties					
Oil phase	Bottom oil	Bottom oil	Top oil	Top oil	Top oil
C dry (wt. %)	63.0	66.3	67.7	74.2	73.3
H dry (wt. %)	9.0	9.3	9.7	10.3	9.8
O dry ^b (wt. %)	28.0	24.4	22.6	15.5	16.9
H ₂ O (wt. %)	15.9	10.0	5.7	3.2	2.1
HHV _{wet} ^c (MJ/kg)	25.2	28.7	31.3	35.8	35.1
MCRT (wt. %)	11.7	9.1	4.7	1.8	2.2
MCRT of 20 wt % blend in Long Residue ^d (wt. %)	3.2	2.9	2.2	1.9	2.0
Gas composition					
CO ₂ (mol %)	81.8	48.4	53.1	58.7	61.0
CO (mol %)	0.8	4.6	2.0	1.4	1.2
CH ₄ (mol %)	14.1	24.7	22.5	21.4	22.1
C ₂ H ₆ -C ₃ H ₈ (mol %)	3.3	21.7	22.2	18.5	15.7

^a Definition on the calculation of dry yields can be found elsewhere [7]

^b As difference

^c Higher heating value calculated using Reed's equation [25]

^d MCRT of Long Residue = 2.04 wt. %

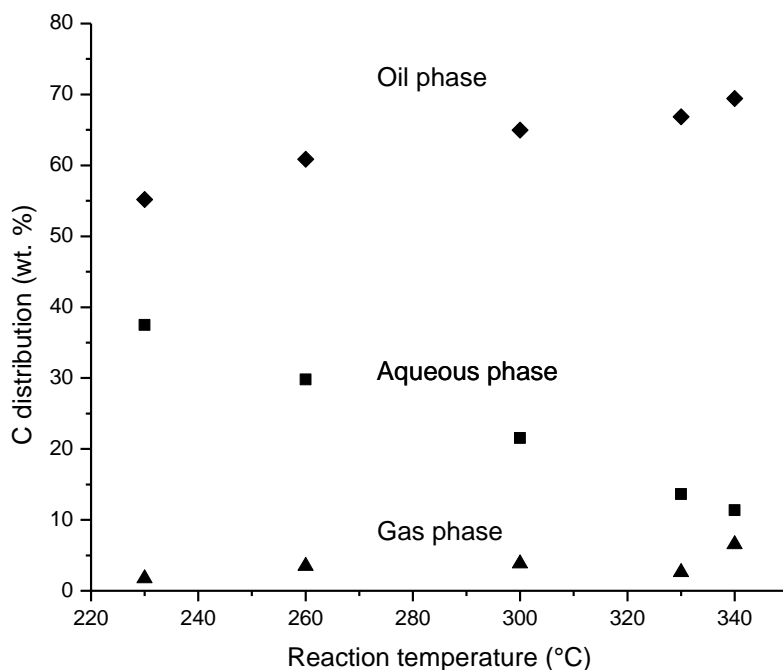

Figure 3. Carbon distribution in the HDO products at different reaction temperature. (◆) Oil phase yield, (■) aqueous phase yield, (▲) gas phase yield.

In [Figure 4](#), the Van Krevelen diagram shows the molar O/C and H/C ratios of the feed oil, its water insoluble fraction (obtained by mixing water and pyrolysis oil [26], water:oil weight ratio of 0.35) and the product oils. It shows that even at the lowest temperature the O/C was substantially reduced as compared to original pyrolysis oil (at 230 °C: O/C ~ 0.33; original pyrolysis oil O/C ~ 0.53) and this ratio decreased further with temperature (at 340 °C: O/C ~ 0.17). The deoxygenation at low temperature seems to be mainly caused by an aqueous/organic phase split (with a large fraction of the oxygenated components being transferred to the aqueous phase), as water addition to pyrolysis oil did also yield an oil with similar O/C as the HDO oil obtained at 230 °C. Nevertheless, the H/C of the HDO oils always was substantially higher than that of the water insoluble fraction obtained after adding water to pyrolysis oil. Surprisingly, the further increase in HDO temperature did not lead to an increase, but a small but consistent decrease, in the H/C ratio. There are three possible explanations for this effect. Firstly, the hydrogenation reactions (for example saturation of double bonds or formation of alcohols from aldehyde/ketone functionality [27]) might be favoured at lower temperature and therefore, these reactions could take place during the heating up period (100-200 °C) and afterwards hydrodeoxygenation/dehydration could be dominant. This phenomenon has been observed for guaiacol [19] and phenol [28]. The occurrence of low temperature hydrogenation is further supported when the O/C of the oil produced at 230 °C is compared to the water insoluble fraction of pyrolysis oil (obtained by water addition); the H/C is significantly increased by the HDO process while the O/C remains the same. Secondly, total pressure is made up of water, hydrogen and gases and vapours

formed during the HDO process. When the total pressure dropped below the set-point, hydrogen was added again to reach the pressure set-point. However, due to a gradual increase in partial pressure of the gaseous and volatile reaction products, and the use of a constant total pressure, the partial hydrogen pressure decreased during the course of an experiment. Therefore, the hydrogen availability decreased for further reactions that could lead to an increase of the H/C ratio. An estimation of the final H₂ partial pressure during the reaction at 340 °C taking into account the vapour pressure of water, and the partial pressure of the permanent gases (based on gas analysis after the experiment, see [Table 2](#)) shows that there could only have been a maximum of 42 bar of H₂ at the end of the reaction period (in fact, it might have been lower as various light components present in the reaction mixture also had a substantial partial pressure at those conditions and are not taken into account by this estimation). Finally, the organics that are being transferred from the aqueous phase to the oil phase (see [Figure 3](#)), could have a lower H/C ratio than the ones already present in the oil phase, thereby reducing the overall ratio.

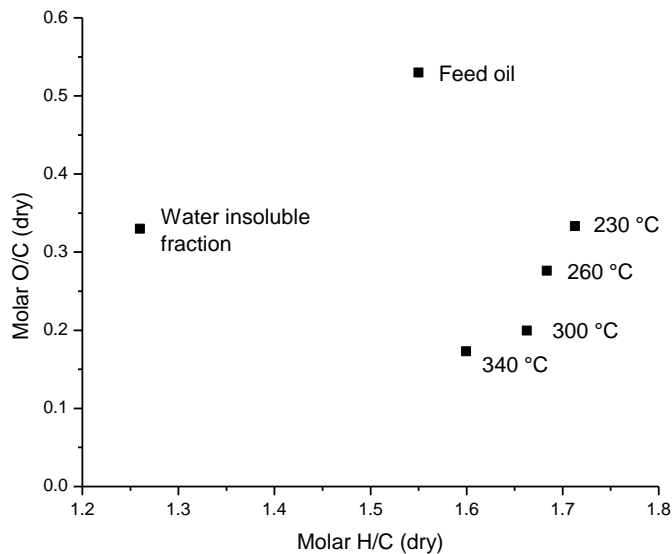

Figure 4. Van Krevelen diagram of the oil product after HDO of pyrolysis oil at different reaction temperature (4h, 290 bar), compared to the feed oil and the water insoluble fraction.

To obtain information about the type of components being transferred from the aqueous phase to the oil phase, VTT's solvent fractionation technique was applied to the aqueous phase product. In [Figure 5](#), it can be seen that the ether insoluble fraction (consisting mainly of sugars) decreased with temperature. Therefore, the product of the conversion of sugars could be the cause of the increase of the carbon recovery in the oil phase. This effect of transfer of sugars was already observed during the HPTT of pyrolysis oil [7]. However, in that case, the sugars underwent polymerisation creating a very viscous oil with substantially increased molecular weight as compared to the original pyrolysis oil. GPC analyses of the molecular weight of the feed oil, the HDO oils and a HPTT oil are shown in [Figure 6](#). It can be seen that when using this Ru/C

catalyst and hydrogen, the typical polymerisation reactions observed during HPTT seem to be avoided and/or the high molecular weight components (including any possible polymerisation product) underwent hydrocracking reducing their amount or even disappearing. Although GPC separates the components by size and not by weight and HDO reactions could have changed the first, leaving the latter almost untouched, the viscosity of the oils also decreased at higher HDO reaction temperatures, from 471 to 57 cP (measured at 20 °C, HDO temperature 230 °C and 340 °C, respectively) supporting the GPC results.

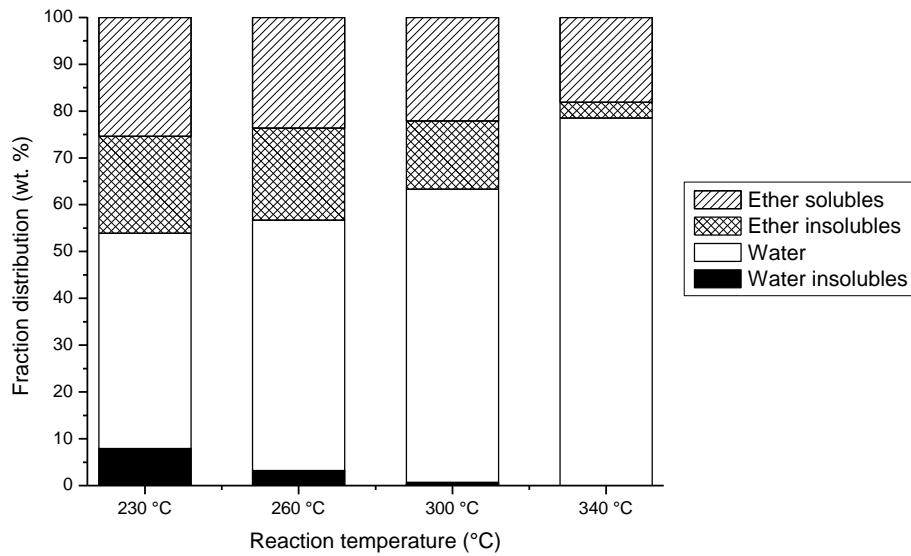

Figure 5. Results of VTT's solvent fractionation technique applied to the aqueous phase product obtained at various HDO reaction temperatures.

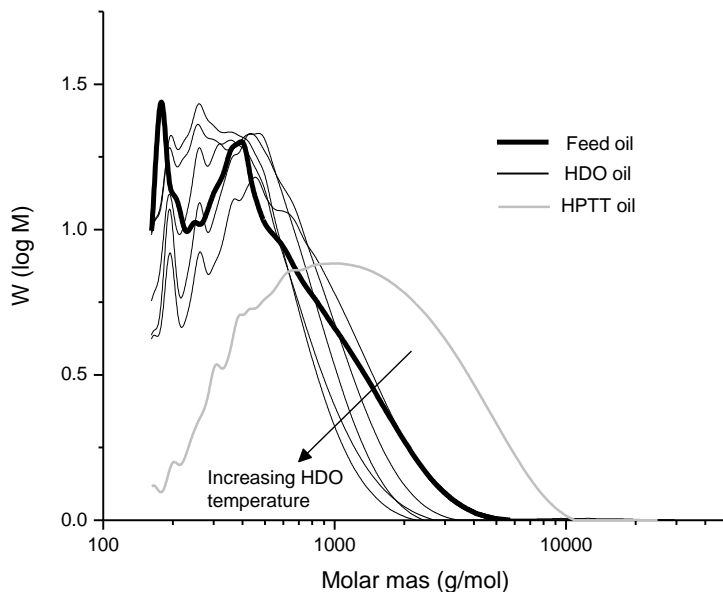

Figure 6. Molecular weight distribution obtained by GPC analysis of the original pyrolysis oil (feed oil), the oil products obtained by HDO at different reaction temperatures (230 °C, 260 °C, 300 °C, 330 °C and 340 °C) and 4h, 290 bar and the product of HPTT of pine oil at 300 °C, 3.2 min and 200 bar [7].

3.2. Catalytic cracking of upgraded oil in a MAT reactor

Prior to co-processing the HDO oils in the MAT reactor, miscibility tests oils of these HDO oils in Long Residue were performed. Although the miscibility at room temperature was limited, especially for the oils obtained at low HDO temperature, after mixing and heating to 75 °C the HDO oil was miscible in the Long Residue FCC feed. This was checked by using the same Long Residue/HDO oil mixture in two consecutive experiments and obtaining good product yield reproducibility indicating that separation of the mixture had not occurred in the feed reservoir

Two different types of tests were performed in the MAT reactor. First, 20 wt. % HDO oil in Long Residue was evaluated. Afterwards, HDO oils with relatively low oxygen content (oils processed at 300 and 340 °C) were processed undiluted. For better comparison of the results, FCC product yields are given at a constant 60% conversion. Conversion is defined as the sum of dry gas, LPG, gasoline range (C5 – 221 °C) and coke.

From the TBP analysis of the liquid product obtained after the MAT reactor, together with the coke make (CO₂ detector) and the gas composition, yields of different types of products could be determined: H₂, dry gas, CO, CO₂, propylene, LPG, gasoline, LCO, HCO, slurry oil, and coke. The desired product is mainly gasoline, but LPG and LCO (as diesel precursor) are also considered to be valuable products. Dry gas and especially coke

(in high amounts) are the not desired products. The amounts of H₂, CO, CO₂, propylene, HCO and slurry oil were low (<8 wt. %) and grouped as “other” in the analysis of the results.

It should be noted that all the co-processing experiments were conducted without any plugging issues and the coke and dry gas yields were similar to those obtained using only the Long Residue feed (see [Table 3](#)). The yields are normalised by the amount of water produced, considering that basically all the oxygen present in the HDO oils was converted to water (CO and CO₂ yields were always lower than 0.5 wt. %). Between parentheses, the yields taking into account the produced water are also shown. It can be seen that only a slightly higher Cat/Oil ratio was required when Long Residue/HDO mixtures were processed. [Table 3](#) also shows that at the same conversion level, the yields of the various fractions (values normalised by the amount of produced water) did not differ from each other significantly. This was unexpected taking into account the differences in dry O content ranging from 16.9 to 28.0 wt. %. This indicates that with respect to achieving the required quality for FCC processing of HDO oils, the HDO step might be less severe than traditionally thought to be required, even suggesting that the HDO step at low temperature (the “stabilisation step”) might be enough to enable co-processing. This would reduce hydrogen consumption during pyrolysis oil upgrading. On the other hand, at lower HDO reaction temperature, less carbon was recovered in the oil phase during the HDO step ([Figure 3](#)), reducing the overall carbon efficiency from pyrolysis oil to FCC product. However, the organic components present in the aqueous phase could be used in subsequent processes to generate value added chemicals production or hydrogen (through steam reforming or supercritical water gasification).

Table 3. Product yields at 60 wt. % conversion after catalytic cracking of 20 wt. % HDO oil in Long Residue feed at 520 °C. Yields of products (in wt. %) normalised by amount of produced water. Between paranthesis, yields including produced water. Oxygen content from C H elemental analysis (by difference)

	Long Residue reference	20% HDO 230°C Bottom oil	20% HDO 260°C Bottom oil	20% HDO 300°C Top oil	20% HDO 330°C Top oil	20% HDO 340°C Top oil
Cat/oil ratio	3.1	4.3	3.4	3.4	3.7	3.8
LPG yield	8.5	11.0 (10.1)	10.1 (9.4)	10.2 (9.6)	9.3 (8.9)	9.6 (9.2)
Gasoline yield	44.0	43.7 (40.2)	44.7 (41.7)	46.0 (43.4)	45.3 (43.5)	44.7 (43.0)
LCO yield	25.2	23.1 (21.3)	23.8 (22.2)	23.9 (22.5)	24.8 (23.8)	25.0 (24.0)
Dry gas yield	1.5	2.5 (2.3)	2.3 (2.1)	1.9 (1.8)	2.0 (1.9)	2.1 (2.0)
Coke yield	5.9	7.8 (7.2)	7.1 (6.6)	5.5 (5.2)	5.7 (5.5)	6.0 (5.8)
Other (HCO, Slurry Oil, CO and CO ₂)	14.8	11.7 (10.8)	11.8 (11.0)	12.3 (11.6)	12.7 (12.2)	12.5 (12.0)
Water	-	- (7.9)	- (6.7)	- (5.7)	- (3.9)	- (3.9)

The catalytic cracking of some undiluted HDO oils was shown to be technically feasible for those HDO oils made at more severe upgrading conditions ([Table 4](#)). Compared to the product yields from the catalytic cracking of the Long Residue feed alone or blends thereof with HDO oils, the dry gas and coke yield are significantly higher (compare with Table 3). For the undiluted HDO oils, the coke and dry gas yields also decrease with increasing upgrading severity, whilst the gasoline and LCO yields concomitantly increase. The Cat/Oil ratio required to obtain a 60 wt. % conversion is also

much higher than for co-processing 20 wt. % HDO oils. This shows that co-processing is necessary to obtain good product yields.

Table 4. Product yields at constant 60 wt. % conversion from the catalytic cracking of undiluted HDO oils at 520 °C normalised by amount of produced water. ?

	Pure HDO oil (300°C/295bar)	Pure HDO oil (330°C/300bar)	Pure HDO oil (340°C/290bar)
Cat/Oil ratio	20.2	12	12.6
LPG yield	11.7	10.5	9.7
Gasoline yield	22.3	34.4	36.2
LCO yield	10.9	19.3	18.4
Dry gas yield	10.8	5.6	5.7
Coke yield	37.5	22.4	21.9
Other (HCO, Slurry Oil, CO and CO ₂)	6.7	7.5	7.8

From the results shown in [Table 3](#), a linear extrapolation via 100 wt. % Long Residue and at 20 wt. % HDO oil / 80 wt. % Long Residue gives the putative product yields from a virtual 100 wt. % HDO oil. [Figure 7](#) compares this extrapolated yield with that from actual experimental product yields of the catalytic cracking of undiluted HDO oils (obtained at a HDO temperature of 300 and 340 °C). As expected, linear extrapolation substantially underestimates the coke and dry gas yields. This is probably due to hydrogen transfer, known to be prevalent during catalytic cracking. Another possible cause could be the reduction of the coke formation rate from HDO oil components due to a decrease in the coke precursor concentration by dilution with Long Residue oil. If these coke formation reactions have a reaction order higher than one (for example bimolecular reaction mechanism), then reducing the concentration of HDO oil components by dilution might cause a reduction in the coke yield. The internal hydrogen transfer has been already observed during coal liquefaction [29], and during HDO of pyrolysis oil using hydrogen donor solvents such as tetralin [30]. At this stage, it is impossible to state which of the aforementioned mechanisms actually causes this reduced coke yield.

Surprisingly, bio-hydrocarbon products were obtained with little oxygen, indicating that hydrogen transfer from the refinery feed eliminates the HDO oil oxygen as water. The residual oxygen containing compounds have been identified and quantified by GC*GC*ToF MS ([Table 5](#)) and were substituted phenols (mainly dimethyl). Comparing the HDO oil prepared at 300 °C in both co-processing a 20 % blend and 100 %, the amount of phenols present in the products is much lower (a factor 15 versus expected factor 5).

Table 5. Phenols (ppm wt) in the cat cracking product measured by GC*GC*Time of Flight Mass Spectrometry.

	From catalytic cracking of 20 % blend in Long Residue at 520 °C			From catalytic cracking of 100 % HDO oil at 520 °C		
	20% HDO 230°C Bottom oil	20% HDO 260°C Bottom oil	20% HDO 300°C Top oil	Pure HDO 300°C Top oil	Pure HDO 330°C Top oil	Pure HDO 340°C Top oil
Phenol	2769	1686	1169	12727	10120	9800
3/4-MePhenol	1606	944	730	7179	6799	6634
2,5-DiMePhenol	3223	1660	1194	20227	16400	16192
2,4/5-DiMePhenol	336	164	135	2384	2154	2061
2,3-DiMePhenol	492	276	125	2236	2602	2542
2-MePhenol	1855	1506	1250	11273	10500	10279
2-EtPhenol	1593	765	652	11261	10161	10131
3,5-DiMePhenol	508	221	193	2808	2717	2652
3/4-EtPhenol	382	155	125	2949	2586	2575
Totals phenols	12765	7377	5572	73045	64039	62865

An indication of the quality of the HDO oil with respect to FCC co-processing can be obtained when the coking tendency of the oil is known. This can be obtained by the micro carbon residue test (MCRT). For better comparison, the MCRT results shown in [Table 2](#) for the undiluted HDO oils were scaled to account for the amount of water in the feed, which cannot contribute to the coke formation. The carbon residue from the 20% diluted samples was extrapolated to a virtual 100 % HDO oil to determine the theoretical contribution to the MCRT of the (dry) HDO oil (the MCRT contribution of the Long Residue was corrected for by assuming proportional contributions of this fraction to the total MCRT). The results (see [Figure 8](#)) show that dilution in Long Residue feed generally reduced the theoretical contribution to the MCRT value of the HDO oil, but this effect was much stronger for oils processed at low HDO temperature (especially 230 °C; 260 °C; less at 300 °C) than at high temperature (330 °C; 340 °C) where the difference was hardly noticeable. In a MCRT test the sample is exposed to a thermal treatment, so the MCRT tests gives an indication of the intrinsic –non-catalyzed-charring or polymerization. Apparently the intrinsic charring of HDO oils decreases with HDO reaction temperature. At the same time, Figure 8 shows that intrinsic charring of less stable oils (produced at lower temperature) can be decreased -more than based on the dilution ratio- by dilution with a Long Residue (it should be noted that the more than proportional decrease of MCRT was also be observed in the work of Samolada et al. [13]). A similar phenomenon was observed in the HPTT of pyrolysis oil [7], in which dilution also decreased charring/polymerization. The near equal MCRT values but totally different MAT reactor results for the (20% HDO/80% Long residue) mixture and 100% HDO oil (Table 3 and 4, Figure 7), shows that a low MCRT value of the feed/blend in itself is not enough to realize a good product spec upon FCC processing, This seems logical as the MCRT does not account for hydrogen transfer initiated by catalytic reactions.

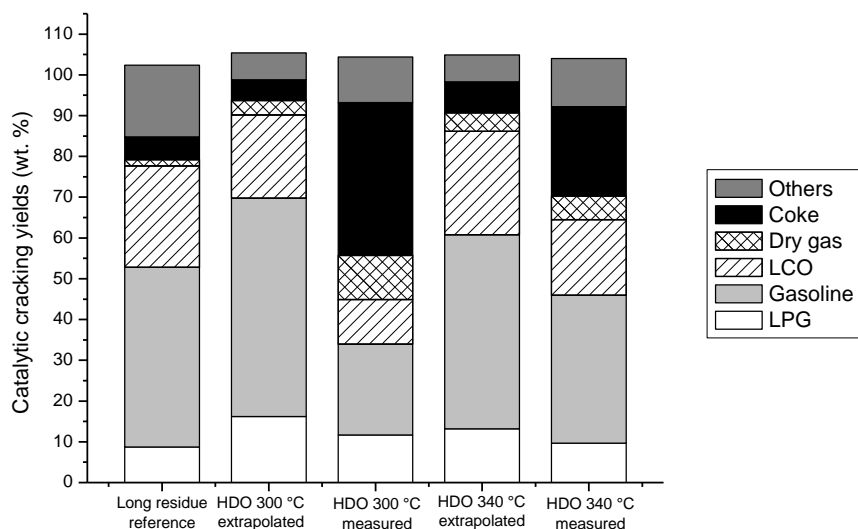

Figure 7. Product yields after catalytic cracking. Results for experiments denoted as “extrapolated” are theoretical yields obtained when extrapolating actual yields at 20% mix HDO oil in Long Residue to 100% HDO oil.

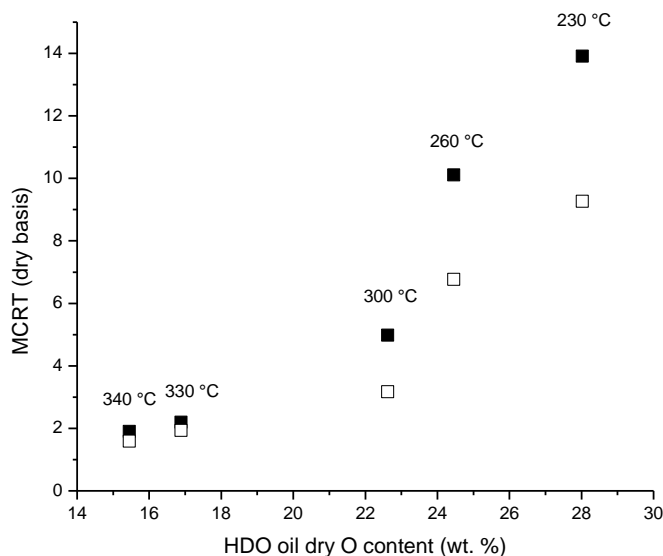

Figure 8. MCRT results (dry basis) of undiluted HDO oil (dry basis, measured, ■) and 20 wt. % HDO oil in Long Residue (dry HDO oil basis, recalculated based on experimental MCRT values for 20 wt. % HDO blend and assumption proportional contribution Long Residue, □). The values above the data points correspond to the temperature of the HDO treatment.

4. Discussion

The decrease of oxygen content of pyrolysis oil can be achieved by HDO. This already known fact [5] was, until now, considered to be the goal of HDO and the remaining level of oxygen *the* parameter that determines the quality of the HDO oil with respect to further use like FCC. Low oxygen levels (<10 wt. %) were targeted in most of the available literature [13, 14, 31]. However, this work has shown that high remaining levels of oxygen can be allowed in upgraded HDO oil (up to 28 wt. %) without deterioration of the yield structure after lab scale FCC co-processing. In general in FCC the coking tendency of the feed, which can be expressed by the MCRT, should be low to technically allow FCC processing (for the MAT reactor as used in this study the maximum MCRT is about 5%). The MCRT of normal FCC feeds is typically less than 0.5 wt. % [32]. This study shows that the MCRT of pure HDO oil can be lowered -sometimes more than proportional- using a suitable co-processing solvent. A low MCRT_{blend} (low in relation to FCC process it is used in) seems a prerequisite for co-processing, but does not guarantee a good product yield structure. In addition miscibility also seems a requirement, but for the HDO oils as used in this study good miscibility was obtained in all cases. In FCC the H/C (mole basis) is another parameter used to express the quality of the (fossil) feed: an increase in H/C generally results in more high value products like gasoline [32, 33]. For biomass and also HDO oil, an effective H/C_{eff} can be used (Chen et al [34], Corma et al.[35]). In the absence of nitrogen and sulphur this parameter is defined as $H/C_{eff} = (H - 2 \cdot O)/C$, the correction reflecting the net oxygen removal (dry oil) via water production. The H/C_{blend} (feedstock MAT reactor) can be determined from the H/C_{eff} (dry HDO oil) the H/C_{fossil fuel} and the weight based mixing ratio (based on dry HDO oil). Although the use of the MCRT_{blend} and the H/C_{blend} might just be a start in the definition of product quality for HDO oil (blends) in FCC co-processing, this type of approach is needed to come to a proper definition and quantification of HDO oil quality for FCC co-processing. In relation to this study and comparing the HDO with the HPTT [7] of pyrolysis oil, both processes produce an oil phase and reduce the oxygen content (HPTT yields an oil with a dry oxygen content of ~ 20 wt. %). However, HPTT oil could not be processed in the MAT reactor because of its high coking tendency (MCRT on dry basis of 45.1 wt. %). For these HPTT oils the molecular weight distribution strongly increased during HPTT upgrading as compared to the original pyrolysis oil. In contrast, for the HDO oils, as reported in this study, the molecular weight distribution remained similar during upgrading or even decreased, which is an indication of the thermal stability of these HDO oils reflected by a relatively low MCRT (especially for the blends). These results on HDO oils are in line with the ones from Ardiyanti et al.[36], although they report the TGA residue instead of a MCRT. These blended HDO oils also had good co-processing performance although in pure form even the HDO oil produced at a reaction temperature of 340 °C (MCRT pure and blend near equal) did not give a good yield structure in the MAT reactor which might be attributed to the low H/C_{eff} of the pure feed as compared to the 20% blend (H/C_{eff} at 340 °C only 1.26); H/C_{blend}=1.67).

During the HDO process, hydrogenation of reactive groups (such as olefins, aldehydes and ketones) at relatively low temperatures of 100-200 °C [27] seems to play a critical role to obtain thermally stable molecules/feed suitable for further processing in a FCC unit (i.e. low MCRT). These reactions appear to be in competition with the

polymerisation reactions (as already seen by Gagnon and Kaliaguine [37]). In [Figure 9](#) a schematic impression of the competition between polymerization and stabilisation is given; a similar view of this competition is reported by Venderbosch et al. [38]. Depending on the operating conditions and parameters, such as heating rate/temperature and hydrogen mass transfer rate, it may be possible to steer the ratio of the heterogeneous HDO reaction to the homogeneous polymerization reaction and thereby influence product quality. These fast polymerisation reactions (not counteracted by fast enough hydrogenation reactions) seem to be cause of the reactor plugging reported in literature when pyrolysis oil was directly fed to continuous HDO reactors at high temperature [8].

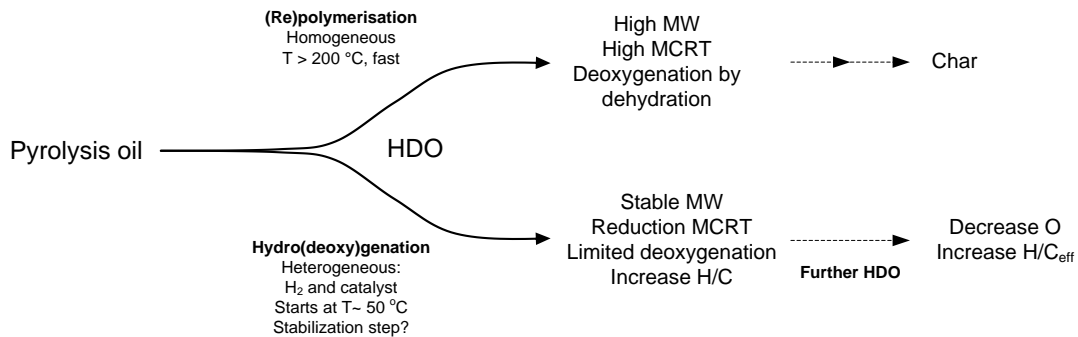

Figure 9. Schematic overview of the competition between polymerisation and hydro(deoxy)genation reaction during HDO process (MCRT, micro carbon residue test; MW, molecular weight). See also [38].

HDO reactions lead to a better product (with respect to FCC co-processing) but at the expense of hydrogen. In contrast, the product of HPTT has a lower quality but it is simpler to produce (neither catalyst nor hydrogen is needed). For a continuous process, a balance between product quality and economics (carbon recovery in oil, H₂ consumption, operating conditions, reactor volume, type and amount of catalyst, etc.) should be found which may result in a reactor configuration that integrates both the HDO and HPTT process step. As part of this, it should be noted that the assessment of the (required) quality of upgraded (HDO) oil should always be done in relation to, and in combination with, the mixing ratio and quality of the typical FCC feed.

5. Conclusions

Co-processing hydro deoxygenated pyrolysis oils having an oxygen content up to 28 wt. % under standard lab scale FCC conditions gives gasoline and LCO range bio hydrocarbons from a ligno-cellulosic feed source with similar product yields as that obtained from the base FCC feed.

After the HDO step, pyrolysis oil underwent phase separation into an aqueous phase and one or two oil phases. An increase in the process temperature led to an oil with lower oxygen content and to the transfer of organic components (sugar-type) from the aqueous phase to the oil phase. In contrast to the thermal treatment of pyrolysis oil, this transfer was not due to polymerisation of the sugars but due to their hydrodeoxygenation. Therefore, the molecular weight of the oil did not increase during the process. At the highest temperatures, the average molecular weight even decreased, probably due to the cracking of heavy components. The increase of the H/C_{eff} ratio and the reduction in reactivity of some functional groups (likely olefins, aldehydes, ketones...), that avoided further polymerisation, appeared to be a key factor to reduce the coking tendency and improve yield structure during catalytic cracking. It should be noted that higher HDO temperatures were accompanied by higher H_2 consumption on a kg feed basis (increasing from 232 to 326 NL H_2 /kg feed) but on a MJ product basis hydrogen consumption was similar within 8% (~22 NL H_2 /MJ).

Despite the significant differences between the properties of the HDO oils, similar and promising results were obtained from their co-processing with a heavy oil petroleum fraction (Long Residue) which might be attributed to a similar $MCRT_{\text{blend}}$ and H/C_{blend} . There are two main observations from these results. Firstly, the possibility to successfully co-process HDO oils with high oxygen content (28.0 wt. % in dry basis) without an extreme increase in coke formation. Secondly, the absence of a co-processing solvent (Long Residue in the present work) caused an increase of the undesired products (coke, dry gas...) yields by reducing the production of valuable products (gasoline, LCO...). This indicates that, as long as the catalytic cracking is done in the presence of a suitable co-feed present in sufficient quantity, the HDO step does not need to aim towards full deoxygenation, but only to the reduction of the highly reactive components/functional groups that lead to coke formation and prevent successful co-processing.

Acknowledgements

The authors would like to acknowledge the EU for partial funding of the work through the BIOCOUP project within the 6th Framework Program (contract number: 518312) and the CORAF project of Senter Novem (project number EOSLT04018). We also would like to thank the partners of the BIOCOUP project, especially VTT (Finland) for performing part of the analyses and R.H.Venderbosch (BTG) and H.J. Heeres (Rijks Universiteit Groningen) for the discussions on the role of, and phenomena during HDO upgrading. The MSc student A.A.F. Hulsman (UT) is acknowledged for carrying out part of the experimental work.

References

1. D. Pimentel, T.W. Patzek, Ethanol Production Using Corn, Switchgrass, and Wood; Biodiesel Production Using Soybean and Sunflower, *Natural Resources Research* 14 (2005) 65-76.
2. A. Oasmaa, S. Czernik, Fuel oil quality of biomass pyrolysis oils-State of the art for the end users, *Energy Fuels* 13 (1999) 914-921.
3. E. Hoekstra, K.J.A. Hogendoorn, X. Wang, R.J.M. Westerhof, S.R.A. Kersten, W.P.M. van Swaaij, M.J. Groeneveld, Fast Pyrolysis of Biomass in a Fluidized Bed Reactor: In Situ Filtering of the Vapors, *Industrial & Engineering Chemistry Research* 48 (2009) 4744-4756.
4. A.A. Lappas, M.C. Samolada, D.K. Iatridis, S.S. Voutetakis, I.A. Vasalos, Biomass pyrolysis in a circulating fluid bed reactor for the production of fuels and chemicals, *Fuel* 81 (2002) 2087-2095.
5. D.C. Elliott, Historical developments in hydroprocessing bio-oils, *Energy Fuels* 21 (2007) 1792-1815.
6. R.K. Sharma, N.N. Bakhshi, Catalytic upgrading of pyrolysis oil, *Energy & Fuels* 7 (1993) 306-314.
7. F. De Miguel Mercader, J.A. Hogendoorn, R.H. Venderbosch, S.R.A. Kersten, M.J. Groeneveld, Pyrolysis oil upgrading by high pressure thermal treatment, (2009)
8. D.C. Elliott, E.G. Baker, Hydrotreating biomass liquids to produce hydrocarbon fuels, in: D.L. Klass Editor, *Energy from Biomass and Waste X*, Institute of Gas Technology, Chicago, 1987, pp. 765-784.
9. D.C. Elliott, G.G. Neuenschwander, Liquid fuels by low-severity hydrotreating of biocrude, in: A.V. Bridgwater and D.G.B. Boocock Editors, *Developments in Thermochemical Biomass Conversion*, Blackie Academic & Professional, London, 1996, pp. 611-621.
10. J.D. Adjaye, N.N. Bakhshi, Production of hydrocarbons by catalytic upgrading of a fast pyrolysis bio-oil. Part I: Conversion over various catalysts, *Fuel Processing Technology* 45 (1995) 161-183.
11. R.K. Sharma, N.N. Bakhshi, Upgrading of wood-derived bio-oil over HZSM-5, *Bioresource Technology* 35 (1991) 57-66.
12. W. Baldauf, U. Balfanz, M. Rupp, Upgrading of flash pyrolysis oil and utilization in refineries, *Biomass and Bioenergy* 7 (1994) 237-244.
13. M.C. Samolada, W. Baldauf, I.A. Vasalos, Production of a bio-gasoline by upgrading biomass flash pyrolysis liquids via hydrogen processing and catalytic cracking, *Fuel* 77 (1998) 1667-1675.
14. A.A. Lappas, S. Bezergianni, I.A. Vasalos, Production of biofuels via co-processing in conventional refining processes, *Catalysis Today* 145 (2008) 55-62.
15. T.L. Marker, J.A. Petri, *Gasoline and diesel production from pyrolytic lignin produced from pyrolysis of cellulosic waste*. 2007: United States.
16. www.biocoup.eu. Last visited on 09-09-09.
17. A. Oasmaa, E. Kuoppala, S. Gust, Y. Solantausta, Fast pyrolysis of forestry residue. 1. Effect of extractives on phase separation of pyrolysis liquids, *Energy Fuels* 17 (2003) 1-12.

18. J. Wildschut, H.J. Heeres, Experimental studies on the upgrading of fast pyrolysis oil to liquid transportation fuels, Preprints of Symposia - American Chemical Society, Division of Fuel Chemistry 53 (2008) 349-350.
19. A. Gutierrez, R.K. Kaila, M.L. Honkela, R. Slioor, A.O.I. Krause, Hydrodeoxygenation of guaiacol on noble metal catalysts, Catalysis Today In Press, Corrected Proof (2009)
20. V.A. Yakovlev, S.A. Khromova, O.V. Sherstyuk, V.O. Dundich, D.Y. Ermakov, V.M. Novopashina, M.Y. Lebedev, O. Bulavchenko, V.N. Parmon, Development of new catalytic systems for upgraded bio-fuels production from bio-crude-oil and biodiesel, Catalysis Today 144 (2009) 362-366.
21. B.E. Poling, J.M. Prausnitz, J.P. O'Connell, The properties of gases and liquids, Fifth ed., McGraw-Hill, United States, 2001.
22. A. Michels, W. De Graaff, T. Wassenaar, J.M.H. Levelt, P. Louwerse, Compressibility isotherms of hydrogen and deuterium at temperatures between -175°C and + 150°C (at densities up to 960 amagat), Physica 25 (1959) 25-42.
23. A. Oasmaa, E. Kuoppala, Y. Solantausta, Fast pyrolysis of forestry residue. 2. Physicochemical composition of product liquid, Energy Fuels 17 (2003) 433-443.
24. D.C. Elliott, L.J. Sealock, E.G. Baker, Chemical processing in high-pressure aqueous environments. 2. Development of catalysts for gasification, Industrial & Engineering Chemistry Research 32 (1993) 1542-1548.
25. E.S. Domalski, T.L. Jobe (Jr.), T.A. Milne, Thermodynamic data for biomass materials and waste components. The American Society of Mechanical Engineers, New York, 1987.
26. D. Radlein, The production of chemicals from fast pyrolysis bio-oils, in: A.V. Bridgwater Editor, Fast pyrolysis of biomass. A handbook, CLP Press, Newbury, Berkshire, 1999, pp. 164-185.
27. E. Laurent, C. Pierret, P. Grange, B. Delmon. *Control of the deoxygenation of pyrolytic oils by hydrotreatment*. in *Proc. of 6th conference on Biomass for energy, industry and environment*. 1991. Athens, Greece.
28. E.-J. Shin, M.A. Keane, Gas-Phase Hydrogenation/Hydrogenolysis of Phenol over Supported Nickel Catalysts, Industrial & Engineering Chemistry Research 39 (2000) 883-892.
29. R.C. Neavel, Liquefaction of coal in hydrogen-donor and non-donor vehicles, Fuel 55 (1976) 237-242.
30. S. Zhang, Y. Yan, T. Li, Z. Ren, Upgrading of liquid fuel from the pyrolysis of biomass, Bioresource Technology 96 (2005) 545-550.
31. S.B. Jones, J.E. Holladay, C. Valkenburg, D.J. Stevens, C.W. Walton, C. Kinchin, D.C. Elliott, S. Czernik, *Production of Gasoline and Diesel from Biomass via Fast Pyrolysis, Hydrotreating and Hydrocracking: A Design Case*. 2009, US Department of Energy.
32. R. Sadeghbeigi, Fluid catalytic cracking handbook. Gulf Professional Publishing, Houston, 2000.
33. E. Mariaca-Domínguez, R. Maya-Yescas, S. Rodríguez-Salomón, A. González-Ortíz, G.E. Martínez-Tapia, R. Álvarez-Ramírez, C. López-Franco, Reactivity of Fluid Catalytic Cracking Feedstocks as a Function of Reactive Hydrogen Content, Petroleum Science and Technology 22 (2004) 13 - 29.

34. N.Y. Chen, T.F. Degan Jr., L.R. Koenig, Liquid fuel from carbohydrates, *Chemtech* 16 (1986) 506-511.
35. A. Corma, G.W. Huber, L. Sauvanaud, P. O'Connor, Processing biomass-derived oxygenates in the oil refinery: Catalytic cracking (FCC) reaction pathways and role of catalyst, *Journal of Catalysis* 247 (2007) 307-327.
36. A.R. Ardiyanti, R.H. Venderbosch, H.J. Heeres. *Process-product studies on pyrolysis oil upgrading by hydrotreatment with Ru/C catalysts*. in *Proceedings of the 2009 AIChE Spring National Meeting*. 2009. Tampa, FL, US.
37. J. Gagnon, S. Kaliaguine, Catalytic hydrotreatment of vacuum pyrolysis oils from wood, *Ind. Eng. Chem. Res.* 27 (1988) 1783-1788.
38. R.H. Venderbosch, A.R. Ardiyanti, J. Wildschut, A. Oasmaa, H.J. Heeres, Insights in the hydroprocessing of biomass derived pyrolysis oils, to be published, copy available at www.btgworld.com (2009).